

Night Bell Over Paging Adapter

The **K-600F** eliminates the installation of multiple bells, relays, and power supplies, wherever night bells, loud ringing, or emergency tones are required. The **K-600F** provides an existing paging amplifier with a pleasant electronic warble tone each time it receives ring voltage from an analog PABX/KSU extension.

The **K-600F** requires no external power supply and provides a floating 600 ohm audio output. Paging In and Out terminals are provided to allow automatic switching between paging and warble audio when used with an existing paging installation. A set of N.O. / N.C. relay contacts are provided that switch in cadence with the ring signal. Volume and tone controls are also provided.



Features

- Powered by ring signal – no external power supply required
- Provides tone over existing paging amplifiers
- Terminals for automatic switching between paging audio and warble tone
- Auxiliary relay contacts provided
- Connects directly to ringing analog PABX/KSU stations with RJ11 or terminals
- Floating 600 ohm audio output
- LED indication of unit activation
- Wall mount housing: (2) #6x3/4 panhead screws included

Applications

- Night bell over paging
- Loud ringing over paging
- Contact closure on ringing
- Visual indication of ringing

Specifications

Power: Phone line powered
Ring Voltage: 40VAC / 20Hz minimum
Ringer Equivalence: 1.0A REN
Shipping Weight: 0.5lbs (0.2kg)
Dimensions: 4.5" x 3.0" x 1.5" (114mm x 76mm x 38mm)
Environmental: 32°F to 90°F (0°C to 32°C) with 5% to 95% non-condensing humidity
Audio Output: Floating 600Ω, <0.5Vpp
Maximum Audio Cable Run: 15.24m (50 ft)
Relay Contact Ratings: 0.5A @ 125VAC / 1A @ 30VDC
Connections: (1) RJ11 jack and 10 position screw terminal strip

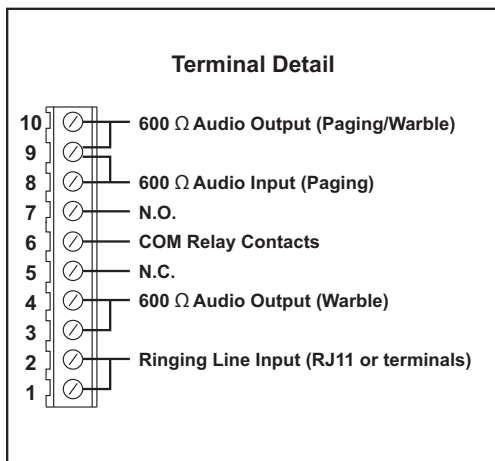

A. Standard Installation

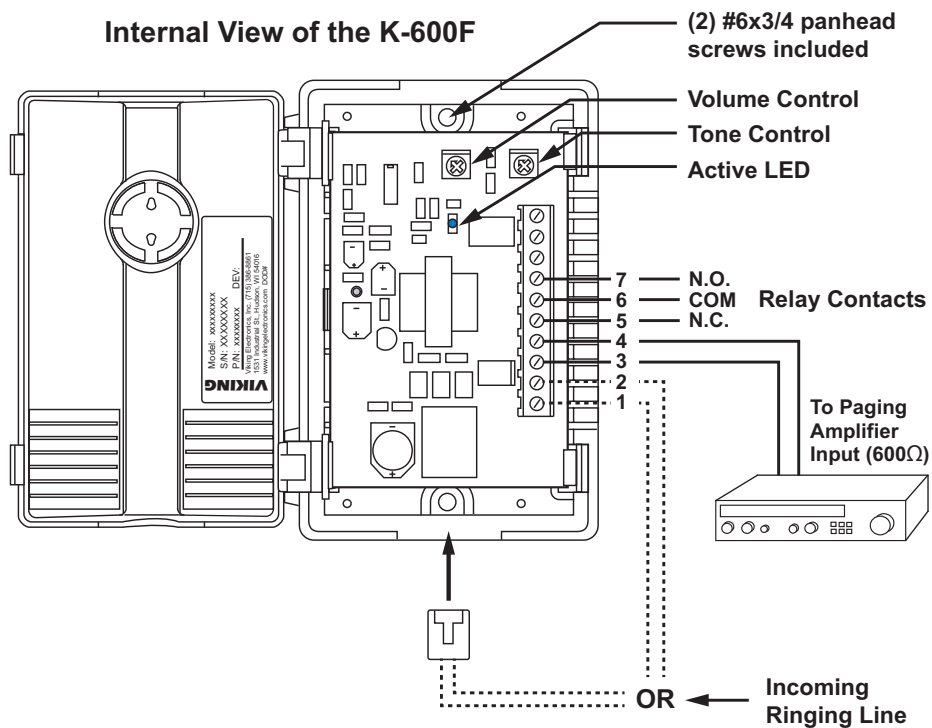

B. Sharing Paging Amplifier Installation

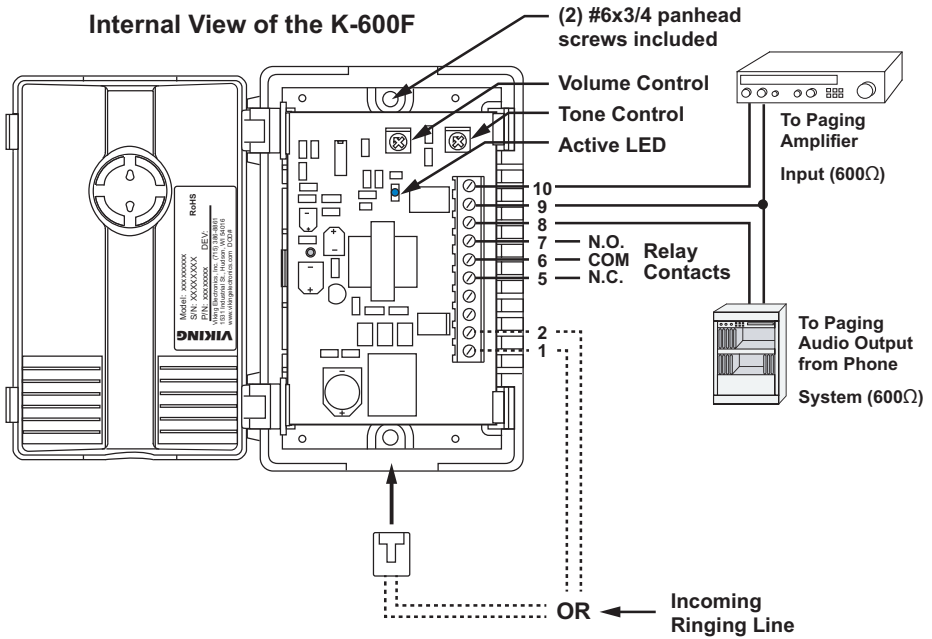

Operation

Upon detecting standard AC ring voltage on the RINGING LINE IN jack or terminals, the **K-600F** will produce a 600Ω warble tone and light the Active LED in cadence with the ring signal. In addition, the normally open relay contacts will close, and the normally closed relay contacts will open. If the installation is sharing the paging amplifier and the unit is connected as shown in diagram B, it will also switch out the paging audio and produce the warble tone through the paging amplifier, switching paging audio back when the ring signal ends.

Warranty

IF YOU HAVE A PROBLEM WITH A VIKING PRODUCT, CONTACT VIKING TECHNICAL SUPPORT AT: 715-386-8666

Our Technical Support Department is available for assistance Monday to Friday 8:00am - 5:00pm central time. Before you call, please:

1. Know the model number, the serial number, and what software version you have (see serial label).
2. Have the Product Manual in front of you.
3. It is best if you are on site.

RETURNING PRODUCT FOR REPAIR

The following procedure is for equipment that needs repair:

1. Customer must contact Viking's Technical Support Department at 715-386-8666 to obtain a Return Authorization (RA) number. The customer MUST have a complete description of the problem, with all pertinent information regarding the defect, such as options set, conditions, symptoms, methods to duplicate problem, frequency of failure, etc.
2. Packing: Return equipment in original box or in proper packing so that damage will not occur while in transit. The original product boxes are not designed for shipping - an overpack box is required to prevent damage in transit. Static sensitive equipment such as a circuit board should be in an anti-static bag, sandwiched between foam and individually boxed. All equipment should be wrapped to avoid packing material lodging in or sticking to the equipment. Include ALL parts of the equipment. C.O.D. or freight collect shipments cannot be accepted. Ship cartons prepaid to:

**VIKING ELECTRONICS
1531 INDUSTRIAL STREET
HUDSON, WI 54016**

3. Return shipping address: Be sure to include your return shipping address inside the box. We cannot ship to a PO Box.
4. RA number on carton: In large printing, write the RA number on the outside of each carton being returned.

RETURNING PRODUCT FOR EXCHANGE

The following procedure is for equipment that has failed out-of-box (**within 10 days of purchase**):

1. Customer must contact Viking's Technical Support at 715-386-8666 to determine possible causes for the problem. The customer MUST be able to step through recommended tests for diagnosis.
2. If the Technical Support Product Specialist determines that the equipment is defective based on the customer's input and troubleshooting, a Return Authorization (RA) number will be issued. This number is valid for fourteen (14) calendar days from the date of issue.
3. After obtaining the RA number, return the approved equipment to your distributor. Please reference the RA number on the paperwork being shipped back with the unit(s), and also the outside of the shipping box. The original product boxes are not designed for shipping - an overpack box is required to prevent damage in transit. Once your distributor receives the package, they will replace the product over the counter at no charge. The distributor will then return the product to Viking using the same RA number.
4. **The distributor will NOT exchange this product without first obtaining the RA number from you. If you haven't followed the steps listed in 1, 2 and 3, be aware that you will have to pay a restocking charge.**

TWO YEAR LIMITED WARRANTY

Viking warrants its products to be free from defects in the workmanship or materials, under normal use and service, for a period of two years from the date of purchase from any authorized Viking distributor. If at any time during the warranty period, the product is deemed defective or malfunctions, return the product to Viking Electronics, Inc., 1531 Industrial Street, Hudson, WI., 54016. Customer must contact Viking's Technical Support Department at 715-386-8666 to obtain a Return Authorization (RA) number.

This warranty does not cover any damage to the product due to lightning, over voltage, under voltage, accident, misuse, abuse, negligence or any damage caused by use of the product by the purchaser or others. This warranty does not cover non-EWP products that have been exposed to wet or corrosive environments. This warranty does not cover stainless steel surfaces that have not been properly maintained.

NO OTHER WARRANTIES, VIKING MAKES NO WARRANTIES RELATING TO ITS PRODUCTS OTHER THAN AS DESCRIBED ABOVE AND DISCLAIMS ANY EXPRESS OR IMPLIED WARRANTIES OR MERCHANTABILITY OR FITNESS FOR ANY PARTICULAR PURPOSE.

EXCLUSION OF CONSEQUENTIAL DAMAGES. VIKING SHALL NOT, UNDER ANY CIRCUMSTANCES, BE LIABLE TO PURCHASER, OR ANY OTHER PARTY, FOR CONSEQUENTIAL, INCIDENTAL, SPECIAL OR EXEMPLARY DAMAGES ARISING OUT OF OR RELATED TO THE SALE OR USE OF THE PRODUCT SOLD HEREUNDER.

EXCLUSIVE REMEDY AND LIMITATION OF LIABILITY. WHETHER IN AN ACTION BASED ON CONTRACT, TORT (INCLUDING NEGLIGENCE OR STRICT LIABILITY) OR ANY OTHER LEGAL THEORY, ANY LIABILITY OF VIKING SHALL BE LIMITED TO REPAIR OR REPLACEMENT OF THE PRODUCT, OR AT VIKING'S OPTION, REFUND OF THE PURCHASE PRICE AS THE EXCLUSIVE REMEDY AND ANY LIABILITY OF VIKING SHALL BE SO LIMITED.

IT IS EXPRESSLY UNDERSTOOD AND AGREED THAT EACH AND EVERY PROVISION OF THIS AGREEMENT WHICH PROVIDES FOR DISCLAIMER OF WARRANTIES, EXCLUSION OF CONSEQUENTIAL DAMAGES, AND EXCLUSIVE REMEDY AND LIMITATION OF LIABILITY, ARE SEVERABLE FROM ANY OTHER PROVISION AND EACH PROVISION IS A SEPARABLE AND INDEPENDENT ELEMENT OF RISK ALLOCATION AND IS INTENDED TO BE ENFORCED AS SUCH.

Product Support: 715-386-8666

Due to the dynamic nature of the product design, the information contained in this document is subject to change without notice. Viking Electronics, and its affiliates and/or subsidiaries assume no responsibility for errors and omissions contained in this information. Revisions of this document or new editions of it may be issued to incorporate such changes.