

## Generate Multiple Tones for Any Paging System

The model **MTG-10** is a multi-tone generator designed to add multiple contact-controlled audio tones to paging systems or 600 ohm inputs.

The **MTG-10's** audio input can be connected to any paging source, ie: phone system paging port or background music. When a contact closure is provided to one of the inputs, the paging or background music is faded out and the appropriate tone is generated over the paging system. The siren or the evacuation whoop always have priority and over-ride any other tone being generated.



The **MTG-10** can also be configured to provide a tone every 15 seconds to notify callers that their conversation is being recorded.

### Tone Descriptions

- Siren
- Interrupted 784Hz Tone
- Door Chime (Ding-Dong)
- Warble (Electronic Ring)
- Fast Whoop
- Hi-Low Siren
- March Time Horn
- All Clear
- Double Gong
- Evacuation Whoop (ANSI/NFPA compliant, temporal slow whoop)
- Telephone Recording Disclosure Tone (250ms beep, every 15 seconds)
- Double Chime
- Quadruple Chime
- Double Buzz or Steady Buzz

### Applications

- 15 available tones, organized into four groups of five tones
- Contact initiated
- Built-in background audio source fade-in/out
- Priority ANSI compliant evacuation and siren tones
- Telephone recording disclosure tone repeats every 15 seconds

### Specifications

- Power:** 120V AC/12V DC 500mA UL listed adapter provided
- Dimensions:** 74mm x 53mm x 25mm (2.9" x 2.1" x 1.0")
- Shipping Weight:** 0.4 kg (0.86 lbs)
- Environmental:** 0°C to 32°C (32°F to 90°F) with 5% to 95% non-condensing humidity
- Input Impedance:** 600 ohms
- Output:** Capable of driving 600 to 100K ohms impedance
- Maximum Output Level:** +8dbm into 600 ohms
- Evacuation Tone:** ANSI compliant
- Connection:** 10 position cage clamp terminal strip

# Installation

## A. Mounting

The **MTG-10** is designed to be wall mounted using the included foam tape or with screws as follows:

<b>Step 1.</b>	Unsnap the plastic cover (see <b>Diagram A</b> right).
<b>Step 2.</b>	Loosen the screw and rotate the circuit board to the left, exposing the two mounting holes in the base (see <b>Diagram B</b> right).
<b>Step 3.</b>	Screw the base to the wall, etc. using (2) #6 flathead or sheetrock screws.

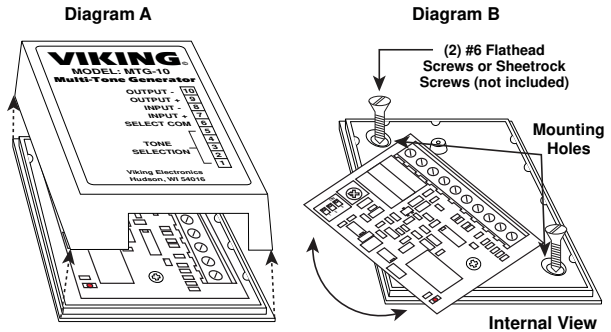

## B. Wiring

**IMPORTANT:** Electronic devices are susceptible to lightning and power station electrical surges from both the AC outlet and the telephone line. It is recommended that a surge protector be installed to protect against such surges.

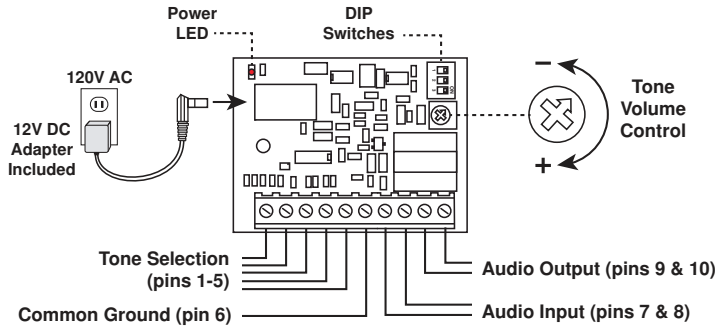

# Programming

## A. Tone Group Selection

The **MTG-10** features 4 groups of user controllable tones which are selected with DIP switches 1 and 2. See the diagram below and chart to the right.

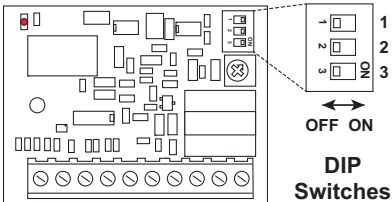

Tones		DIP Switch		Pin
		1	2	
<b>Group 1</b>	Siren			1
	Buzzer (Steady)			2
	Door Chime (Ding Dong)	OFF	OFF	3
	Warble (Electronic Ring)			4
	Double Gong			5
<b>Group 2</b>	Evacuation Whoop			1
	Interrupted 784hz Tone			2
	Double Chime	ON	OFF	3
	Quadruple Chime			4
	Double Buzz			5
<b>Group 3</b>	Evacuation Whoop			1
	Double Buzz			2
	Siren	OFF	ON	3
	Warble (Electronic Ring)			4
	All Clear (1000 Hz tone)			5
<b>Group 4</b>	Evacuation Whoop			1
	Fast Whoop			2
	Hi-Lo Siren	ON	ON	3
	March Time Horn			4
	All Clear (1000 Hz tone)			5

## B. Individual Tone Selection

An individual tone may be energized by shorting pin 6 (common ground) to the corresponding pin of the desired tone. The tones will continue for as long as the closure is maintained. If background music is passed through the **MTG-10**, it will be faded out during the tone and then faded back in. The tone associated with pin number 1 of each group has priority and will interrupt any other on-going tone.

## C. Tone Volume Control

The output level of the tones can be adjusted by adjusting the **Tone Volume Control** as shown in **Installation section B**. This does not affect the level of the audio input. The overall level of both the tones and the paging/background music can be boosted by 14 dB by setting DIP switch 3 to the ON position.

# Operation

## A. Tone Generator Only

If the **MTG-10** is to be used strictly as a tone generator, connect pins **9 & 10** of the **MTG-10** to the audio input of a paging amplifier. In this mode, no input signal is required, only a contact closure for the desired tone.

## B. Tone Generation and Paging

The **MTG-10** can be installed in between a phone system's paging port and a paging amplifier. Connect the paging port to pins **7 & 8**. The audio output pins **9 & 10** go to the paging amplifier's input. When the **MTG-10** is idle, pages will pass through it to the amplifier. When the **MTG-10** receives a contact closure, it will interrupt any paging audio and play the associated tone for the duration of the closure.

## C. Tone Generation and Background Music Control

If the application requires background music to be interrupted by the tone, connect the background music source to audio input pins **7 & 8**. The audio output pins **9 & 10** connect to the audio input of a paging amplifier.

## D. Telephone Recording Disclosure Tone

In some states, to legally record a telephone conversation, both parties must be alerted to the fact that you are recording their conversation. One common method of reminding callers that they are being recorded is to provide a periodic alert tone during the call. To create a telephone recording disclosure tone at 15 second intervals, wire the **MTG-10** as shown below. When the unit is then powered up, it will go into alert tone mode.

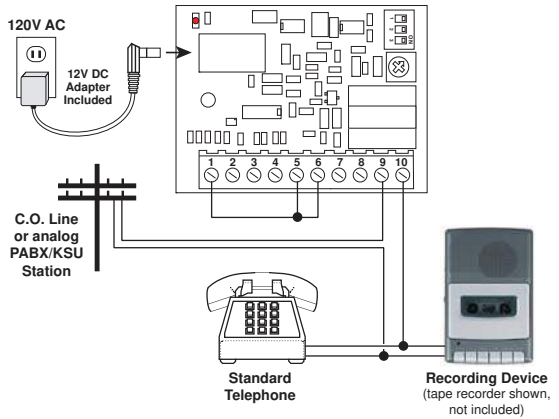

# Applications

## A. Amplifying the MTG-10 Tones with a PA-2A

In this application, the tones from the **MTG-10** are amplified by a Viking **PA-2A** Paging/Loud Ringing Amplifier. Whenever the **MTG-10** receives a contact closure on one of its inputs, it generates the selected tone. Whether the paging amp amplifies the tone when other inputs are activated depends on the the priority the paging amp places on this particular input. If the **MTG-10** has been installed to generate emergency tones, its output should have top priority so that any emergency tone will be amplified and sent to the paging speakers.

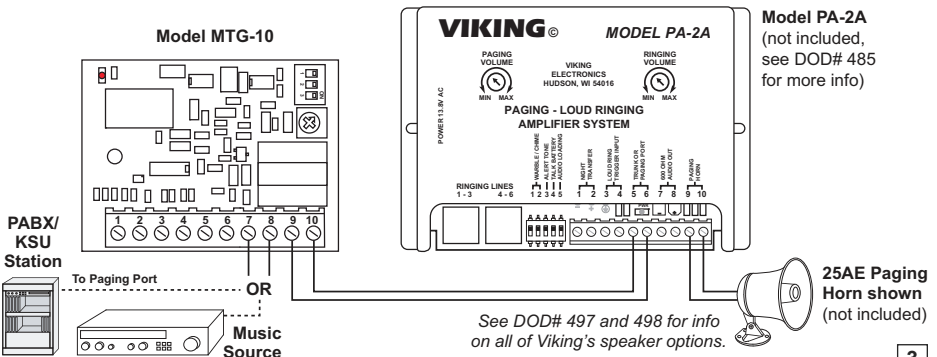

## B. Amplifying the MTG-10 Tones with Paging and Background Music

In this application, the **MTG-10** is used with a Viking **PI-1A** and a **PA-15** to provide paging with background music which can be interrupted by tones from the **MTG-10**. The **PI-1A** provides switching between background music and paging, the **PA-15** provides the amplification, and the **MTG-10** is wired in such a way that its tones will always be given priority over music or paging.

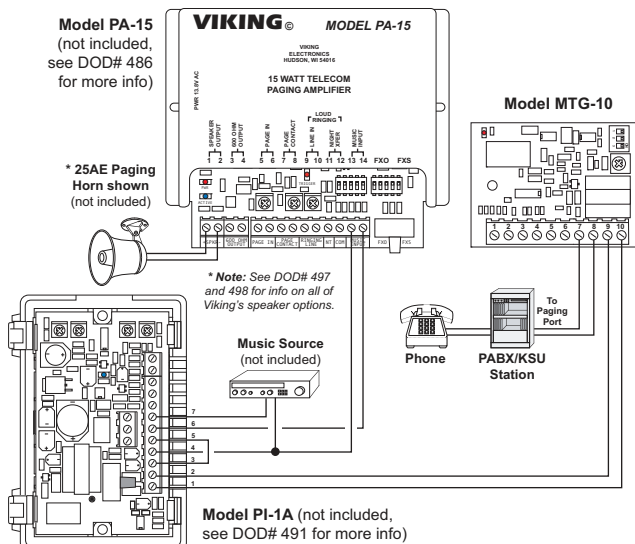

## Warranty

IF YOU HAVE A PROBLEM WITH A VIKING PRODUCT, CONTACT: VIKING TECHNICAL SUPPORT AT (715) 386-8666

Our Technical Support Department is available for assistance Monday 8am - 4pm and Tuesday through Friday 8am - 5pm central time. So that we can give you better service, before you call please:

1. Know the model number, the serial number and what software version you have (see serial label).
2. Have your Technical Practice in front of you.
3. It is best if you are on site.

### RETURNING PRODUCT FOR REPAIR

The following procedure is for equipment that needs repair:

1. Customer must contact Viking's Technical Support Department at 715-386-8666 to obtain a Return Authorization (RA) number. The customer MUST have a complete description of the problem, with all pertinent information regarding the defect, such as options set, conditions, symptoms, methods to duplicate problem, frequency of failure, etc.
2. Packing: Return equipment in original box or in proper packing so that damage will not occur while in transit. Static sensitive equipment such as a circuit board should be in an anti-static bag, sandwiched between foam and individually boxed. All equipment should be wrapped to avoid packing material lodging in or sticking to the equipment. Include ALL parts of the equipment. C.O.D. or freight collect shipments cannot be accepted. Ship cartons prepaid to: **Viking Electronics, 1531 Industrial Street, Hudson, WI 54016**
3. Return shipping address: Be sure to include your return shipping address inside the box. We cannot ship to a PO Box.
4. RA number on carton: In large printing, write the R.A. number on the outside of each carton being returned.

### RETURNING PRODUCT FOR EXCHANGE

The following procedure is for equipment that has failed out-of-box (within 10 days of purchase):

1. Customer must contact Viking's Technical Support at 715-386-8666 to determine possible causes for the problem. The customer MUST be able to step through recommended tests for diagnosis.
2. If the Technical Support Product Specialist determines that the equipment is defective based on the customer's input and troubleshooting, a Return Authorization (R.A.) number will be issued. This number is valid for fourteen (14) calendar days from the date of issue.
3. After obtaining the R.A. number, return the approved equipment to your distributor, referencing the R.A. number. Your distributor will then replace the Viking product using the same R.A. number.
4. The distributor will NOT exchange this product without first obtaining the R.A. number from you. If you haven't followed the steps listed in 1, 2 and 3, be aware that you will have to pay a restocking charge.

## TWO YEAR LIMITED WARRANTY

Viking warrants its products to be free from defects in the workmanship or materials, under normal use and service, for a period of two years from the date of purchase from any authorized Viking distributor. If at any time during the warranty period, the product is deemed defective or malfunctions, return the product to Viking Electronics, Inc., 1531 Industrial Street, Hudson, WI., 54016. Customer must contact Viking's Technical Support Department at 715-386-8666 to obtain a Return Authorization (R.A.) number.

This warranty does not cover any damage to the product due to lightning, over voltage, under voltage, accident, misuse, abuse, negligence or any damage caused by use of the product by the purchaser or others. This warranty does not cover non-EWP products that have been exposed to wet or corrosive environments. This warranty does not cover stainless steel surfaces that have not been properly maintained.

**NO OTHER WARRANTIES.** VIKING MAKES NO WARRANTIES RELATING TO ITS PRODUCTS OTHER THAN AS DESCRIBED ABOVE AND DISCLAIMS ANY EXPRESS OR IMPLIED WARRANTIES OR MERCHANTABILITY OR FITNESS FOR ANY PARTICULAR PURPOSE.

**EXCLUSION OF CONSEQUENTIAL DAMAGES.** VIKING SHALL NOT, UNDER ANY CIRCUMSTANCES, BE LIABLE TO PURCHASER, OR ANY OTHER PARTY, FOR CONSEQUENTIAL, INCIDENTAL, SPECIAL OR EXEMPLARY DAMAGES ARISING OUT OF OR RELATED TO THE SALE OR USE OF THE PRODUCT SOLD HEREUNDER.

**EXCLUSIVE REMEDY AND LIMITATION OF LIABILITY.** WHETHER IN AN ACTION BASED ON CONTRACT, TORT (INCLUDING NEGLIGENCE OR STRICT LIABILITY) OR ANY OTHER LEGAL THEORY, ANY LIABILITY OF VIKING SHALL BE LIMITED TO REPAIR OR REPLACEMENT OF THE PRODUCT, OR AT VIKING'S OPTION, REFUND OF THE PURCHASE PRICE AS THE EXCLUSIVE REMEDY AND ANY LIABILITY OF VIKING SHALL BE SO LIMITED.

IT IS EXPRESSLY UNDERSTOOD AND AGREED THAT EACH AND EVERY PROVISION OF THIS AGREEMENT WHICH PROVIDES FOR DISCLAIMER OF WARRANTIES, EXCLUSION OF CONSEQUENTIAL DAMAGES, AND EXCLUSIVE REMEDY AND LIMITATION OF LIABILITY, ARE SEVERABLE FROM ANY OTHER PROVISION AND EACH PROVISION IS A SEPARABLE AND INDEPENDENT ELEMENT OF RISK ALLOCATION AND IS INTENDED TO BE ENFORCED AS SUCH.

Due to the dynamic nature of the product design, the information contained in this document is subject to change without notice. Viking Electronics, and its affiliates and/or subsidiaries assume no responsibility for errors and omissions contained in this information. Revisions of this document or new editions of it may be issued to incorporate such changes.